

NOVOS 3 x LRW

Radio room operating unit temperature/humidity, optional with CO2



» APPLICATION

LoRaWAN® Room operating unit with recording room temperature and humidity, optionally with CO2 or type dependent occupancy. The transmission of the recorded values, the The transmission of the acquired measured values, the setpoint and optionally a pressed button is done via LoRaWAN® wireless technology.

» TYPES AVAILABLE

Room operating unit LRW

NOVOS 3 T



NOVOS 3 P



NOVOS 3 PT



NOVOS 3 P Occ



» SECURITY ADVICE – CAUTION

The installation and assembly of electrical equipment should only be performed by authorized personnel.



The product should only be used for the intended application. Unauthorised modifications are prohibited! The product must not be used in relation with any equipment that in case of a failure may threaten, directly or indirectly, human health or life or result in danger to human beings, animals or assets. Ensure all power is disconnected before installing. Do not connect to live/operating equipment.

Please comply with

- Local laws, health & safety regulations, technical standards and regulations
- Condition of the device at the time of installation, to ensure safe installation
- This data sheet and installation manual

» MOUNTING ADVISE ROOM SENSORS

The Accuracy of the room sensors are influenced by the technical specifications as well as the positioning and the installation type.

During Assembly:

- Seal mounting box (if present).
- Installation type, air draught, heat source, radiation heat or direct sunlight can affect the measurement.
- Bulding material specific properties of the installation place (*brick-, concrete-, partition wall, cavity wall, ...*) can affect the measurement.

Assembly not recommendet in...

- Air draught (e.g.: close to windows / doors / fans ...)
- Near heating sources,
- Direct sunlight
- Niches / between furniture / ...

» APPLICATION NOTICE FOR HUMIDITY SENSORS

At regular environmental condition, it is recommended to calibrate the sensor annually to check the compliance with the accuracy required in the application. The following conditions can damage the sensor element or lead in long term to loss of the specified accuracy:

- Mechanical stress
- Contamination (e.g. dust / fingerprints)
- Aggressive chemicals
- Ambient conditions (e.g. condensation on measuring element)



Do not touch the sensor elements!

Re-calibration or exchange of the sensor element are not subject of the general warranty.

» INFORMATION ABOUT SELF-CALIBRATION FEATURE CO2

Optical gas sensors are subject to drift. Therefore, the CO2 sensor must be protected from the following environmental conditions, as they accelerate or contribute to aging, wear, or increased measurement errors:

- Mechanical stress (also due to temperature fluctuation)
- Contamination (dust / fingerprints e.g.)
- Abrasive chemicals
- Environmental influences (high humidity / condensation on measuring element)

The sensor is maintenance-free. Self-calibration is based on the “lowest-value principle”: A periodic supply of outside air (window ventilation or outside air mode of the ventilation system) is absolutely necessary to establish the reference value.

The lowest value measured within 15 days is defined as the reference value (400 ppm). If the measured value falls below this level, immediate recalibration is triggered.

If a reduction to outdoor air levels cannot be guaranteed in an application, the use of dual-channel sensors is required (NOVOS 3 LRW 24V).

» INFORMATION ABOUT INDOOR AIR QUALITY CO2

EN 13779 defines several classes for indoor air quality:

Category	CO ₂ content above the content in outdoor air in ppm		Description
	Typical range	Standard value	
IDA1	<400 ppm	350 ppm	Good indoor air quality
IDA2	400.. 600 ppm	500 ppm	Standard indoor air quality
IDA3	600.. 1.000 ppm	800 ppm	Moderate indoor air quality
IDA4	>1.000 ppm	1.200 ppm	Poor indoor air quality

» TECHNICAL DATA

Enclosure	PC V0, pure white, design cover (optional)
Protection	IP20 according to DIN EN 60529
Ambient condition	-20..+70 °C, max. 85% rH non-condensing, with CO2 sensor operating temperature range 0..+50 °C
Mounting	surface mounted on flush-mounting box (Ø=60 mm) or to be mounted flat onto the surface using screws, base part can be mounted and wired separately
Measuring values <i>(type dependent)</i>	Temperature humidity (CO2)
Power supply	1x AA 3.6V lithium battery LS14500 or ER14505 Temporary operation/commissioning possible with 1x 1.5V AA (LR06) (reduced battery life)
Battery life	+/- 5 years (depending on device configuration, network setup, battery-type and ambient conditions)

Set point (P) <i>(optional)</i>	potentiometer
Button (T) <i>(optional)</i>	for presence detection

» Temperature

Measuring range temperature	-20..+70 °C
Accuracy temperature	±0,4K (typ. at 21 °C)

» Humidity

Measuring range humidity	0..100% rH
Accuracy humidity	±2% between 30..70% rH (typ. at 21 °C)

» CO2 *(optional)*

Measuring range CO2	0..5000 ppm
Accuracy CO2	±50 ppm +3 % of reading (typ. at 21 °C, 50% rH, 1015 hPa)

» OCC *(type dependent)*

Measuring variable	Movement
Detection range	Ø=5 m at approx. 2,5 m installation height (max. 5m)
Sensor	PIR (passive Infrared)

» LoRaWAN®

Radio technology	LoRaWAN®
LoRaWAN version	1.0.4
Device class	Class A
Frequency	EU868 (863-870 MHz)
Max. transmission power	+14 dBm (25 mW)
Receiver sensitivity	-137 dBm
Antenna	internal send- / receiver antenna
LoRaWAN Features	Over The Air Activation (OTAA), Adaptive Data Rate (ADR)
Data transmission <i>(configurabel)</i>	Heartbeat interval (default: 1440 min), Measurement-interval (default: 1 min), hysteresis transmission behavior,

» MOUNTING ADVICES

The installation can be performed on the flat wall surface or on a flush-mounted box. A representative place should be selected. Sunshine and draft, e.g. in the installation tube should be avoided, so that the measurement result is not falsified. Seal the end of the installation tube.

- For wiring, the upper part of the device must be removed from the base plate. Base plate and upper part are detachably connected to each other by means of locking lugs.
- The mounting of the base plate on the flat wall surface is done with rawplugs and screws.
- Finally, the device is attached to the base plate and fixed with the screw.

Housing open / close

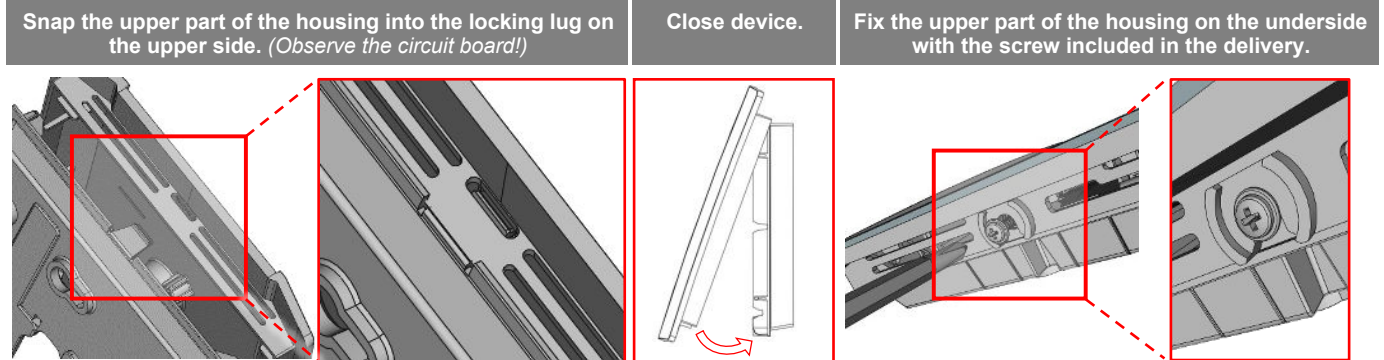

» BATTERY INSTALLATION

The NOVOS 3 INC LRW is designed to be powered by 1x 3.6V lithium battery (LS14500 or ER14505).

Insert the battery as shown. Observe polarity/orientation.

For commissioning and to bridge the gap if lithium batteries are not available, the sensor can also be operated for several months with 1 alkaline manganese battery (LR06).

(Lithium batteries are subject to dangerous goods regulations for shipping and are therefore not included in the scope of delivery.)

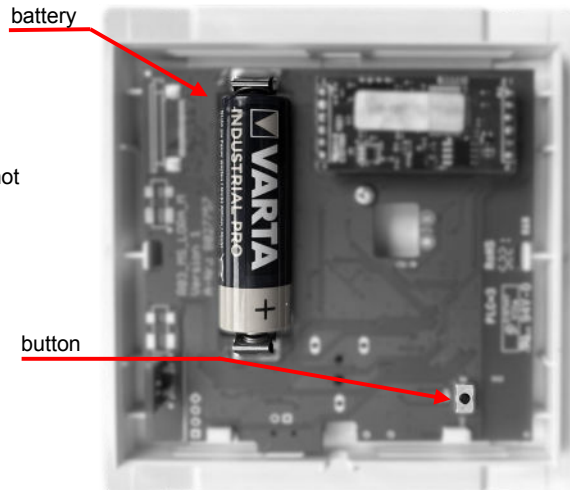

» CONFIGURATION

The configuration is performed in powered state. The following options are available for configuring the device:

Device connection	Micro-USB cable	Bluetooth radio	LoRaWAN® downlink
Configurations- software	PC/Notebook with uConfig software	Smartphone/Tablet with LRWApp	LoRaWAN Infrastructure

The configuration app with the corresponding instructions can be downloaded from the Google Play Store or the Apple App Store.

» **ADVICE FOR BLUETOOTH CONFIGURATION**



Press the button to start Bluetooth communication. After pressing the button, a connection can be established via the app within approx. 20 seconds. This is indicated by a flashing LED.

» **ADVICE FOR COMMISSIONING:**



The LoRaWAN credentials required for commissioning can be read out via the uConfig software or the LRWapp. On request, the LoRaWAN credentials can also be provided in digital form. For this purpose, please contact your respective contact person.



The first CO2 self-calibration (initial calibration) takes place automatically within 4 hours of inserting the battery. During this period, the sensor must be exposed to ambient air for 10 minutes. To prevent measurement errors caused by exhaled air (CO2 accumulation), no one should be present in the room during the initial calibration.

» **FUNCTIONAL DESCRIPTION NOVOS OCC**

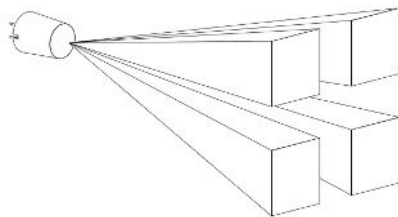

The sensor lens divides the detection area in 32 measurement areas. The sensor detects changes in infrared radiation that occur when an object* (or person) moves that has a different IR temperature than its surroundings

* Object properties:	
Temperature difference (between object and environment)	> +4°C
Object-speed	> 1,0 m/s
Object-size	> 700x250 mm



The motion detector should not be mounted near disturbing heat sources (e.g. lamps, radiators, fans etc.) to avoid false alarms:
Fast temperature changes on the environment can trigger false alarms.

» **DETECTION RANGE (NOVOS 3-OCC)**

Detection range	
Detection distance*	5 m max.
Field of view horizontal	< 90° / 110°
Field of view vertical	< 90° / 110°
Detection zone	32

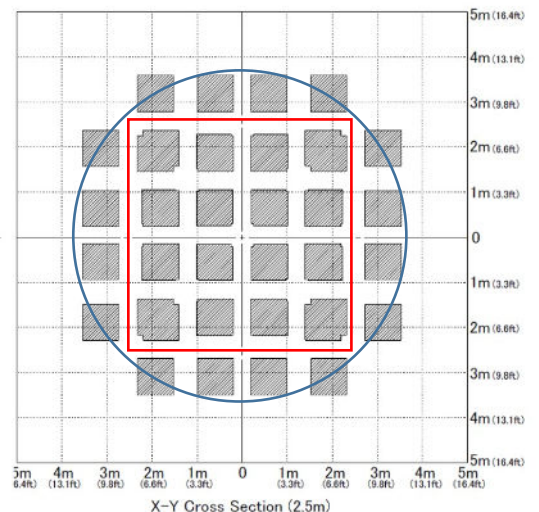
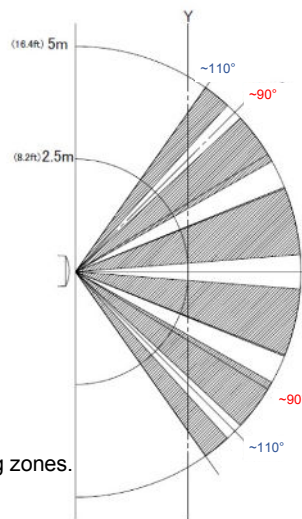

An detection distance of 2,5 m results in a square detection zone of approx. 5 x 5 m, or a circular detection zone of approx. Ø 7 m divided in 32 measuring zones.

Formula: $\tan(\text{field of view}/2) \cdot \text{detection distance} = \text{Radius detection range}$

* The specified ranges refer to average conditions and are approximate values.

Function test

A function test ensures that a movement is located in the optical detection area of the sensor. Walk through the detection area after integrating the device in a LoRaWAN® Network and check whether a radio telegram will be sent.

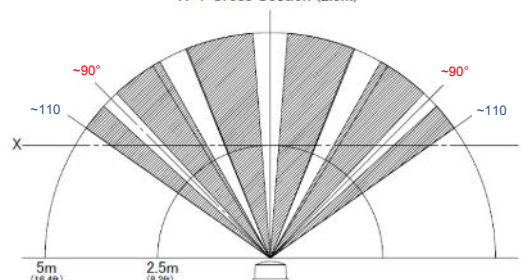

» DIMENSIONS (MM | IN.)

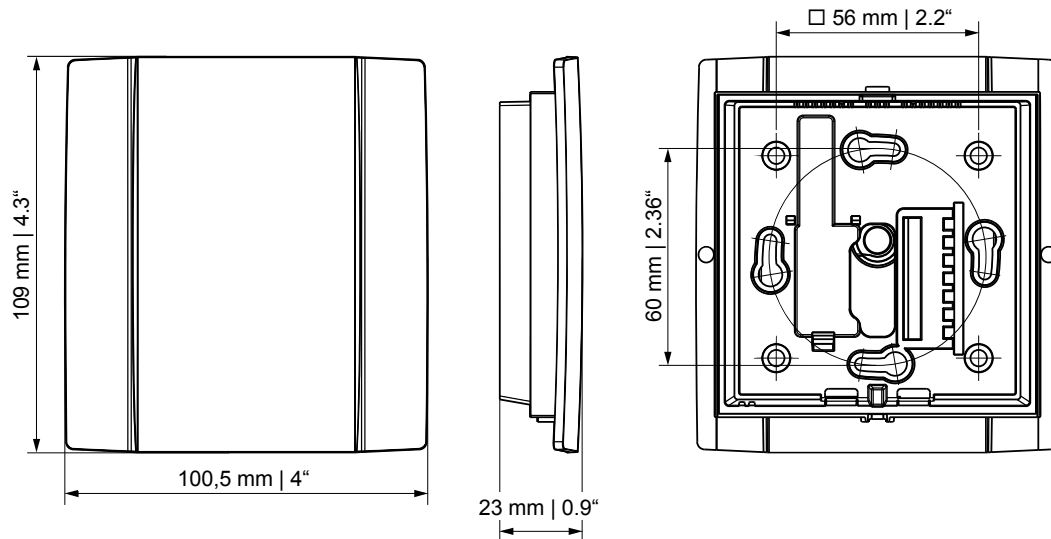

» ACCESSORIES (OPTIONAL)

Rawplugs and screws (2 pcs. each)

Item No.: 660945

Mounting bracket (surface mounted) white
Mounting bracket (surface mounted) black

Item No.: 795050

Item No.: 795074

Battery ER14505 (Lithium Thionyl chloride 3,6V AA)

Item No.: 759182

» NOTES ON DISPOSAL



The crossed-out wheeled bin symbol indicates that the product or removable batteries must not be disposed of with household or commercial waste. Within the EU, you are legally obliged to dispose of the product separately and appropriately in accordance with the national laws of your country.