

MerlinWLM

Water Leak Monitor

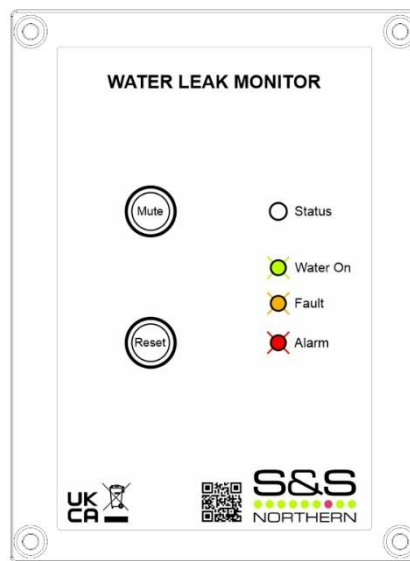

Installation, Operation & Maintenance

Please read this manual carefully and retain for future use.

For specific requirements that may deviate from the information in this guide – contact your supplier.

Contents

Important Warning Statements	3
Installation	4
Typical Application & Location.....	4
Mounting	4
Circuit Board Terminals	5
Wiring – Power	5
Wiring – Water Valve	5
Wiring – Rope Cables/Sensors	6
Basic Operation	7
Controller Status LED	7
Sensitivity	7
Basic Maintenance	8
Specification	8

Important Warning Statements



Where this symbol is used, the manual must be consulted to understand the nature of any potential hazards and how to avoid them.

- ⚠ Before any installation, use or maintenance read this manual carefully.
 - ⚠ The information contained within this manual should be referenced for typical installation and operation only.
 - ⚠ For site specific requirements that may deviate from the information in this guide – contact your supplier.
 - ⚠ If the equipment is used in a manner not specified by the manufacturer, the safety and protection provided by the equipment may be impaired.
 - ⚠ Installation must be in accordance with recognised standards in the country concerned.
 - ⚠ This product is designed for indoor operation only unless used in conjunction with a weatherproof cover.
 - ⚠ Cables must be protected against mechanical damage.
 - ⚠ The internal fuse should be replaced only with the same type. Anti-surge fuse 3.15A 250Vac 5x20.
 - ⚠ This device requires a continual supply of electrical power – it will not work without power.
 - ⚠ A switch or circuit breaker must be fitted, it must be accessible and marked as the disconnecting device!
 - ⚠ Your product should reach you in perfect condition, if you suspect it is damaged, contact your supplier.
-

Manufacturer's Warranty Statement

Warranty coverage: The manufacturer warrants to the original consumer purchaser, that this product will be free of defects in material and workmanship for a period of 3 years from date of purchase.

The manufacturer's liability hereunder is limited to replacement of the product with repaired product at the discretion of the manufacturer. This warranty is void if the product has been damaged by accident, unreasonable use, neglect, tampering or other causes not arising from defects in material or workmanship. This warranty extends to the original consumer purchaser of the product only.

Warranty disclaimers: Any implied warranties arising out of this sale, including but not limited to the implied warranties of description, merchantability and intended operational purpose, are limited in duration to the above warranty period. In no event shall the manufacturer be liable for loss of use of this product or for any indirect, special, incidental, or consequential damages, or costs, or expenses incurred by the consumer or any other user of this product, whether due to a breach of contract, negligence, strict liability in tort or otherwise. The manufacturer shall have no liability for any personal injury, property damage or any special, incidental, contingent, or consequential damage of any kind resulting from water leakage or damage. This warranty does not affect your statutory rights.

Warranty Performance: During the above warranty period, your product will be replaced with a comparable product if the defective product is returned together with proof of purchase date. The replacement product will be in warranty for the remainder of the original warranty period or for six months – whichever is the greatest.

Information on waste disposal for consumers of electrical & electronic equipment.



When this product reaches the end of its life it must be treated as Waste Electrical & Electronics Equipment (WEEE). WEEE marked products must not be mixed with general household waste, but kept separate for the treatment, recovery and recycling of the materials used. Please contact your supplier or local authority for details of recycling schemes in your area.

Every effort is made to ensure the accuracy of this document; however, S&S can assume no responsibility for any errors or omissions in this document or their consequences. S&S would greatly appreciate being informed of any errors or omissions that may be found in the content of this document. For information not covered in this document, or if there is a requirement send comments/corrections, please contact S&S using the contact details.

Installation

Typical Application & Location

⚠ Installation must be in accordance with recognised standards in the country concerned.

The Water Leak Monitor (WLM) is designed to isolate the water supply if water leak has been detected. The controller can be easily manually reset once water leak has been rectified.

Mounting

- ⚠ If mounting direct to wall - ensure the wall surface is flat to prevent base distortion!
- ⚠ Where suitable cable glands/conduits are used for wire entry, use 20mm (3/4 inch) separated by at least 20mm!
- ⚠ Fill any holes drilled to maintain integrity of the equipment!
- ⚠ Restrain the hazardous live wiring from accidental loosening to prevent wires from moving after installation and touching parts of opposite polarity or at low voltages!
- ⚠ A switch or circuit breaker must be fitted, it must be accessible and marked as the disconnecting device!
- ⚠ Isolate the equipment from all hazardous live power sources before opening the cover!

1. Carefully remove the front cover from the unit by using an M3 socket wrench.
2. Using the rear base - mark mounting holes to the wall or align with an appropriate gang/pattress box.
3. Fixing straight to wall – drill 0.2" (5mm) hole, insert plugs and use the four screws (No.4 Pozi) provided.
Alternatively – Fix direct to a vertical 2-gang/double electrical pattress box.
4. There are pre-fractured areas for cable entry on the rear of the base and pilot holes positioned on the top and bottom of the enclosure suitable for entry points up to 3/4" (20mm). Drill out as necessary ensuring all swarf is removed from the box and holes have smooth edges.
5. Secure the front cover with all M4 bolts and insert security caps provided.

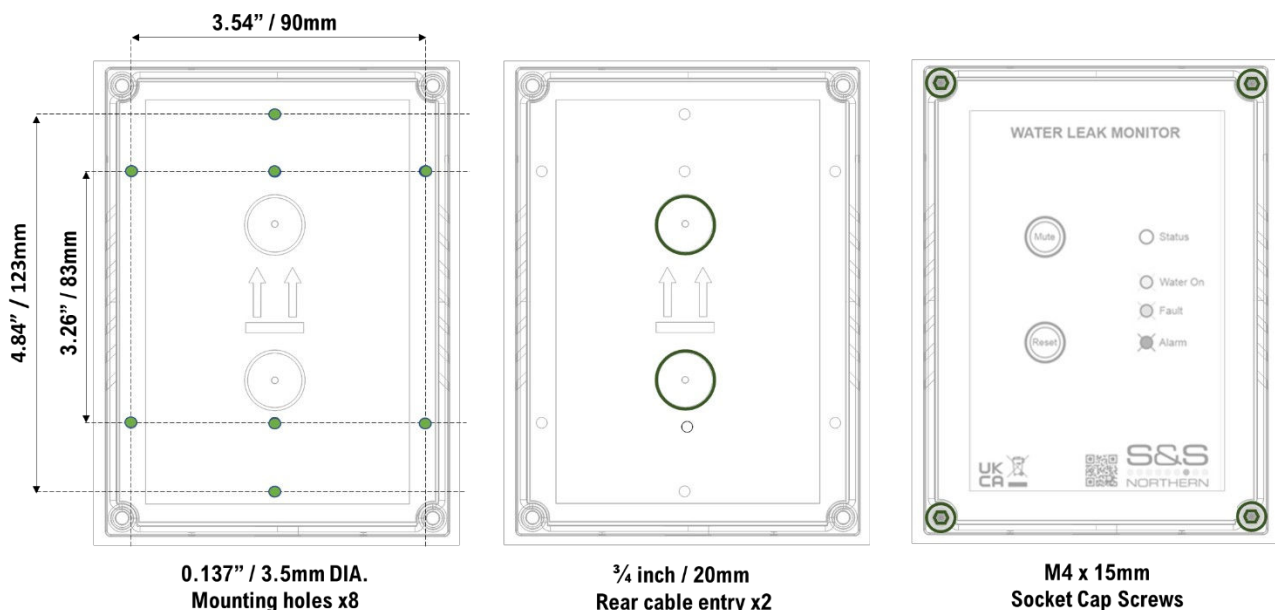

Circuit Board Terminals

- ⚠ **Damage to PCBs when creating cable entry points may void any warranty!**
- ⚠ **Take care when making connections to high voltage connectors!**
- ⚠ **Any damage attempting to remove the circuit board may void any warranty!**
- ⚠ **All Class 2 wiring is to be installed within flexible tubing to maintain segregation between circuits!**
- ⚠ **Wiring of different circuits shall be separated by means of routing, clamping or barrier!**
- ⚠ **A switch or circuit breaker must be fitted, it must be accessible and marked as the disconnecting device!**
- ⚠ **Terminals are pluggable for ease of wiring and therefore subject to misplacement resulting in a hazardous condition!**

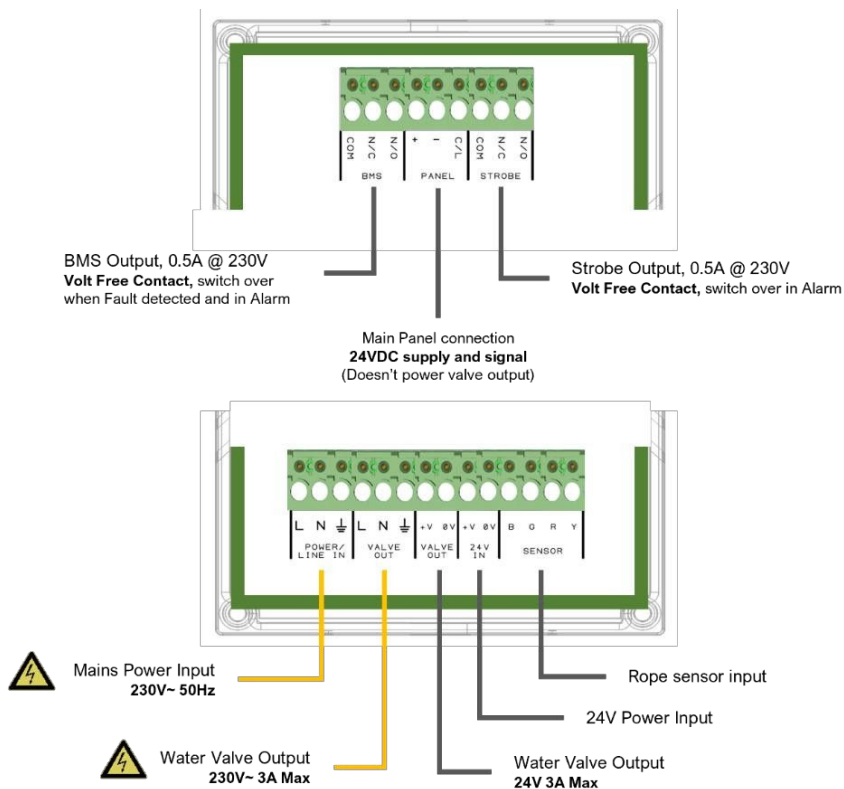

Wiring – Power

The controller requires a power supply of 230V~ wired to the [POWER/LINE IN] terminal using a 3A switched fused spur. Alternatively, the unit can be powered from 24V supply wired to the [24V IN] terminal. This can be AC or DC. When power is connected/live, a red LED will illuminate on the front of the controller on the S&S logo. The controller can also be powered from WLDZ2/4 panel when connected to the [PANEL] terminal.

Please note, this supply doesn't power valve output. Additional 230V or 24V supply is required when this controller is used in conjunction with water solenoid valve.

Wiring – Water Valve

- ⚠ **Use earth terminals for water valves not considered class II apparatus!**
- ⚠ **Connecting two valves to both mains 230V~ and 24V~ simultaneously is considered misuse!**

A water solenoid valve should be powered using one of the terminals marked [VALVE OUT]. Terminals offer control via 230VAC or 24VAC/DC. When wired to a normally closed water solenoid valve, the controller can be used to isolate the water supply when water leak is detected.

Wiring – Rope Cables/Sensors

- ⚠ **When installing leakage detection cables, do not install near high temperatures/fire sources, strong magnetic fields, humid and dusty environments!**
- ⚠ **During laying process, attention should be paid to avoid scratching cables by various sharp objects!**
- ⚠ **Do not overlap ropes/cables – avoid contact with other leak ropes/cables!**

The WLM is compatible with 4 and 2 wire leak ropes wired to the [SENSOR] terminal. This terminal has a factory fitted link (R & Y) and should be removed when 4 wire rope is used.

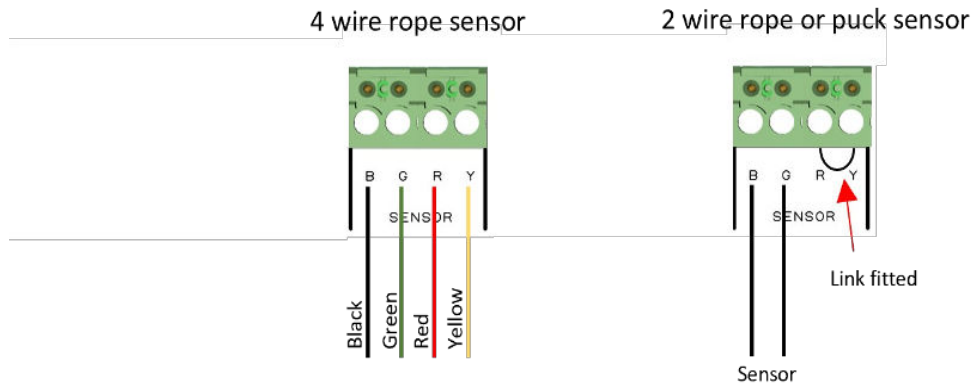

The detection cable can make a timely and accurate response to the leakage of water, weak acid and weak alkali liquid. The cable is small and light, flexible and easy to install. Both ends are equipped with quick transfer terminals, which can be extended quickly.

Other rope/cable considerations when laying.

Avoid

- Using glue compounds
- Laying near or round sharp objects
- Direct contact with metal objects/surfaces
- Installation near air conditioners and other appliances/environments at risk of causing false alarms

Basic Operation



⚠ Isolate the equipment from all hazardous live power sources before opening the cover!

When power is supplied to the controller, the LED on the logo will illuminate Red. To turn the equipment off, disconnect electrical power supply.

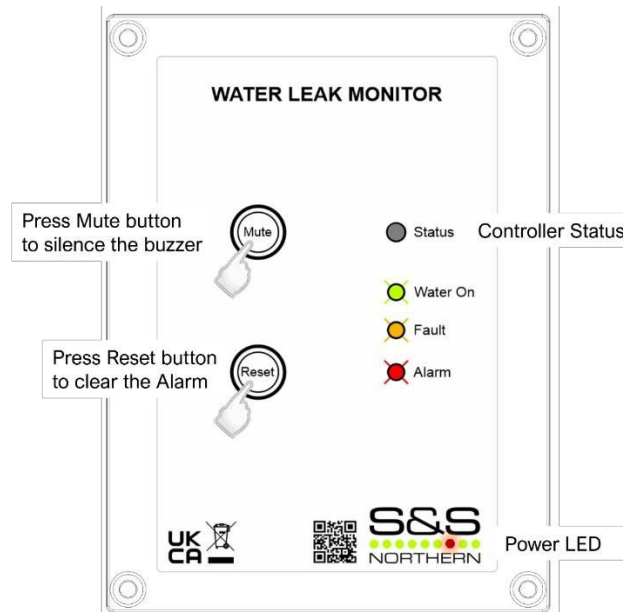
Controller Status LED



The LED changes colour when the controller enters three (3) different states as follows.

-  **Water On.** Green LED remains illuminated when water is being supplied/valve is open (energised).
-  **Fault.** Amber LED remains illuminated when the rope fault is detected. Water supply will remain ON, BMS terminal will switch over. Amber LED will turn Off and BMS terminal will switch back when rope fault has been rectified. *This feature is available only with 4 wire leak rope.*
-  **Alarm.** Illuminated when water leak is detected. Water supply is Off (valve deenergised) until alarm condition has been investigated, rectified, and reset. BMS and Strobe terminals will switch over.

Sensitivity

The potentiometer on the circuit board labelled [SENS] can be used to set the sensitivity of the rope sensor.

- To increase the sensitivity, turn potentiometer clockwise towards MAX position.
- To decrease the sensitivity, turn potentiometer anti-clockwise towards MIN position.



Basic Maintenance

⚠ **Keep your device in good working order - follow these basic principles.**

- ✓ Remove any dust/debris from the outer enclosure regularly using a slightly damp cloth.
- ✓ Never use detergents or solvents to clean your device.
- ✓ Never spray air fresheners, hair spray, paint or other aerosols near the device.
- ✓ Never paint the device.

Specification

General	
Model:	WLM – Water Leak Monitor
Size: (H x W x D)	151 x 111 x 50mm (5.95 x 4.37 x 1.97")
Mounting:	Wall/Surface Mounted. Indoor use only
Weight:	320g (11.2 oz)
User Interface	
Visual Indicators:	LED. Water On / Fault / Alarm
Audible Buzzer:	>60dB @1m (3.28ft). Quiet conditions.
Buttons:	Mute / Reset
Power Supply	
Power Consumption:	1.2W Max
Power Input #1:	100-230V~ 50-60Hz
Power Input #2:	12-24V AC or DC
Internal Fuse:	Anti-Surge 3.15A @ 250Vac
Equipment	
Overvoltage Category:	II
Pollution Degree:	3 (Unit Only)
Relays	
Valve	3A @ 230V~
BMS	0.5A @ 230V~
Strobe	0.5A @ 230V~
Environmental	
Operating temperature	0 ~ 50°C / 32 ~ 122°F 20 ~ 95% RH (non-condensing)
Compliance	
CE / UKCA	
Water Leak Cable	
Cable material	Conductive polyethylene + alloy wire
Core resistance	13.1ohm / m±1%
Cable mass	40g/Metre
Breaking strength	90Kg
Cable diameter	6mm
Exposure temperature	75°C Max